



Catalogo  
**Linea Old Style**  
**Opening**  
**Speciale**  
2020

---

maniglie e accessori

# Indice

	pag.
<b>Linea Old Style</b>	3
Maniglie - <i>Door Handles</i>	5
Maniglioni - <i>Pull Handles</i>	103
Accessori - <i>Accessories</i>	136
Battenti - <i>Door Knockers</i>	137
Pomoli - <i>Knobs</i>	138
Chiavi - <i>Keys</i>	140
Maniglie Incasso - <i>Sliding Handles</i>	141
Nottolini - <i>WC Set</i>	142
Pomolini - <i>Cabinet Knobs</i>	143
Finiture - <i>Finishes</i>	146
Dimensioni - <i>Sizes</i>	146
<b>Linea Opening</b>	150
Maniglie - <i>Door Handles</i>	154
Pomoli - <i>Knobs</i>	180
Cremonesi - <i>Window Handles</i>	184
Maniglioni - <i>Pull Handles</i>	190
Appendiabiti - <i>Coat Hook</i>	198
Accessori - <i>Accessories</i>	204
Copriavvolgibili - <i>Cover Coil for Blinds</i>	204
Coprinterrottori - <i>Switch Cover</i>	204
Manigliette - <i>Handles</i>	207
Chiavi - <i>Keys</i>	208
Nottolini - <i>WC Set</i>	210
Pomolini - <i>Cabinet Knobs</i>	211
<b>Linea Speciale</b>	215
Pomolini - <i>Cabinet Knobs</i>	216

# Linea Old Style

Poche immagini non bastano per far comprendere la qualità e il livello artigianale che rendono così preziosi, particolari e unici questi pezzi che riproducono antiche forme, antichi metodi e antichi stili.

La tecnica è quella di una volta: una rivisitazione di modelli classici ed ora così attuali.  
La lavorazione è quella di una volta: abili artigiani che non si arrendono alla tecnologia.

La cura del prodotto dalla prima all'ultima fase è nostra garanzia di provata qualità.

*A few picture are not enough to let you understand the quality and the craftsmen skill that makes these articles so precious, original and unique, reproducing antique shapes, methods and styles.*

*The technique is the traditional one: sand moulding.  
The design is traditional: a revaluation of classical models, so up-to-date nowadays.  
The manufacture is traditional: skilled artisans not yielding to technology.*

*The care for the product from the very first phase to the last one, is our guarantee of tested quality.*

# Indice

## Linea Old Style

	pag.
Maniglie - <i>Door Handles</i>	5
Maniglioni - <i>Pull Handles</i>	103
Accessori - <i>Accessories</i>	136
Battenti - <i>Door Knockers</i>	137
Pomoli - <i>Knobs</i>	138
Chiavi - <i>Keys</i>	140
Maniglie Incasso - <i>Sliding Handles</i>	141
Nottolini - <i>WC Set</i>	142
Pomolini - <i>Cabinet Knobs</i>	143
Finiture - <i>Finishes</i>	146
Dimensioni - <i>Sizes</i>	146





Art. 460 R



Art. 460 P

Alexandra art. 460



Art. 465 R







Art. 465 P

Alyssa art. 465



Art. 506 R





Art. 506 P

Anny art. 506



Art. 410 R







Art. 410 P

Asia art. 410





Art. 530 R





Art. 530 P

Audrey art. 530



Art. 401 R



Art. 401 C



Art. 401 P

Aurea art. 401





Art. 490 R





Art. 490 P

Carlotta art. 490



Art. 426 R





Art. 426 P

Carmen art. 426





Art. 500 R





Art. 500 P

Cheope art. 500



Art. 420 R



Art. 420 C



Art. 420 P

Circe art. 420





Art. 404 R



Art. 404 C



Art. 404 P

Cometa art. 404



Art. 508 R





Art. 508 P

Cornelia art. 508





Art. 414 R





Art. 414 P

Damasco art. 414



Art. 620 R





Art. 620 P

Domingo art. 620





Art. 538 R





Art. 538 P

Elettra art. 538



Art. 537 R





Art. 537 P

Elizabeth art. 537





Art. 505 R





Art. 505 P

Fiocco art. 505



Art. 411 C



Art. 411 R

Foglia art. 411





Art. 408 R



Art. 408 C



Art. 408 P

Fronda art. 408



Art. 430 R



Art. 430 C





Art. 430 P

Helen art. 430





Art. 507 R





Art. 507 P

Isana art. 507



Art. 535 R





Art. 535 P

Jordan art. 535





Art. 440 R





Art. 440 P

Lucy art. 440



Art. 415 R





Art. 415 P

Marea art. 415





Art. 520 R





Art. 520 P

Monnalisa art. 520



Art. 540 R





Art. 540 P

Morena art. 540





Art. 1050 R





Art. 1040 P

Nadine art. 1040 P



Art. 413 R





Art. 413 P

Najla art. 413





Art. 403 C



Art. 403 R



Nastra art. 403



Art. 421 C



Art. 421 R



Nausicaa art. 421





Art. 550 R





Art. 550 P

Nicole art. 550



Art. 407 R





Art. 407 P

Ninfa art. 407





Ning art. 468 P



Art. 412 C



Art. 412 R



Nodo art. 412



Art. 560 R





Art. 560 P

Noemi art. 560



Art. 425 R





Art. 425 P

Noor art. 425



Art. 509 R







Art. 509 P

Olimpia art. 509



Art. 400 R



Art. 400 C



Art. 400 P

Onda art. 400





Art. 406 R



Art. 406 C





Art. 406 P

Sagoma art. 406



Art. 422 R



Art. 422 C



Art. 422 P

Selene art. 422



Art. 450 R







Art. 450 P

Sofia art. 450



Art. 405 R





Art. 405 P

Sogna art. 405



Art. 570 R







Art. 570 P

Sohan art. 570



Art. 402 R



Art. 402 C



Art. 402 P

Spira art. 402



Art. 480 R





Art. 480 P

Stefani art. 480



Art. 470 R





Art. 470 P

Stenny art. 470



Art. 510 P

Thanya art. 510 P





Art. 466 R



Art. 466 P

Wati art. 466

# Line Old Style

Maniglioni  
*Pull Handles*



— Airone art. 750 MN —





Aurea art. 401 MN



Cheope art. 500 MN



Dea art. 600 MN



— Domingo art. 620 MN —





Eden art. 604 MN



Elfo art. 605 MN

---



Federico art. 759 MN



---

Foglia art. 411 MN

247 mm





Foglia art. 411 MN  
410 mm



— Fronda art. 408 MN



Fronda art. 408 MN  
260 mm



---

Gabriel art. 609 MN



Joele art. 758 MN





— Kira art. 590 MN —

---



Lukas art. 622 MN



— Meteora art. 606 MN



Milagro art. 607 MN



— Monnalisa art. 520 MN —  
260 mm





Monnalisa art. 520 MN  
680 mm



Musa art. 601 MN

---

Najla art. 413 MN  
470 mm



Najla art. 413 MN  
240 mm



---

Najla art. 413 MN  
240 mm - 470 mm



Nausicaa art. 421 MN



— Onda art. 400 MN —

---



Orma art. 602 MN  
480 mm



Orma art. 602 MN  
220 mm

Orma art. 602 MN



Sagoma art. 406 MN

215 mm

---



Sagoma art. 406 MN  
470 mm



Selene art. 422 MN



*Topi'illuminati s.p.a.*



Selva art. 603 MN





— Spira art. 402 MN —

---

# Line Old Style

Accessori

*Accessories*



Art. 700 B



Art. 720 B



Art. 710 B



Art. 525 RPM



Art. 525 PPM

— Monnalisa art. 525 —



Art. 800 R 50



Art. 424 PM



Art. 800 PF 70





Chiave - *Key* art. 902



Chiave - *Key* art. 901



Chiave - *Key* art. 900



Maniglia - *Handle* art. 950

— Chiavi - *Keys* ——— Maniglia - *Handle* ———



Art. 960



Art. 970



Art. 980

— Maniglie Incasso - *Sliding Handles* —



Art. 670 NT



Art. 680 NT

# Line Old Style

Pomolini

*Cabint Knobs*





774 P



557 P



336 P



663 P



668 P



669 P



446 P



447 P



448 P



553 P



554 P



555 P



551 P



771 P



444 P





665 P



662 P



664 P



661 P



666 P



552 P



338 P



442 P



334 P



441 P



558 P



445 P



667 P



449 P



331 P



772 P



332 P



335 P



773 P



333 P



556 P



443 P



337 P

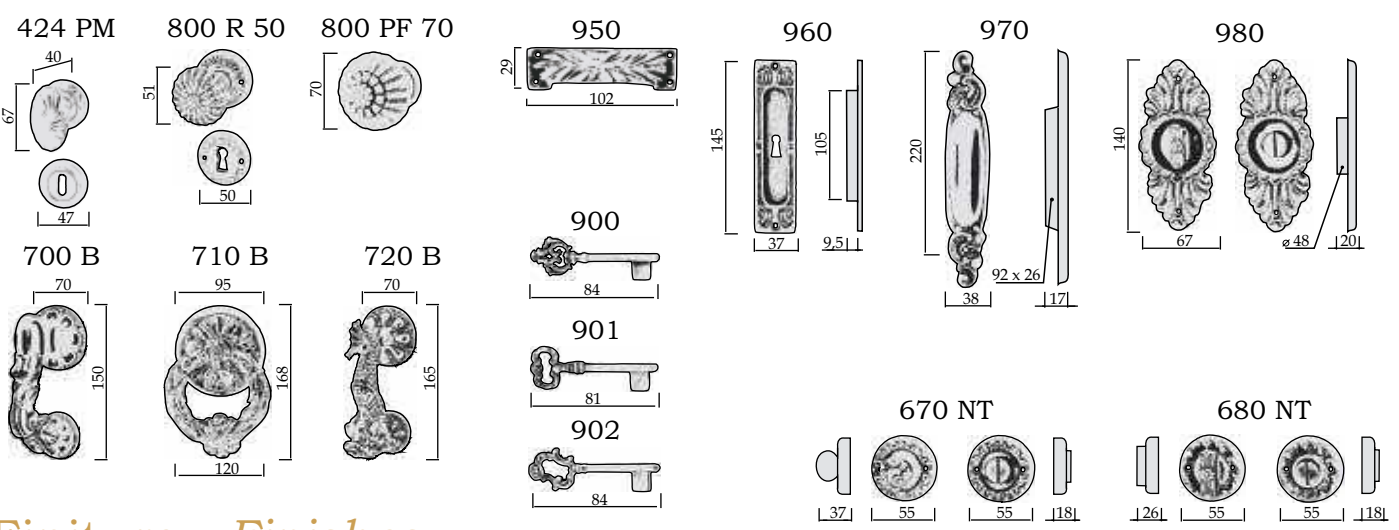
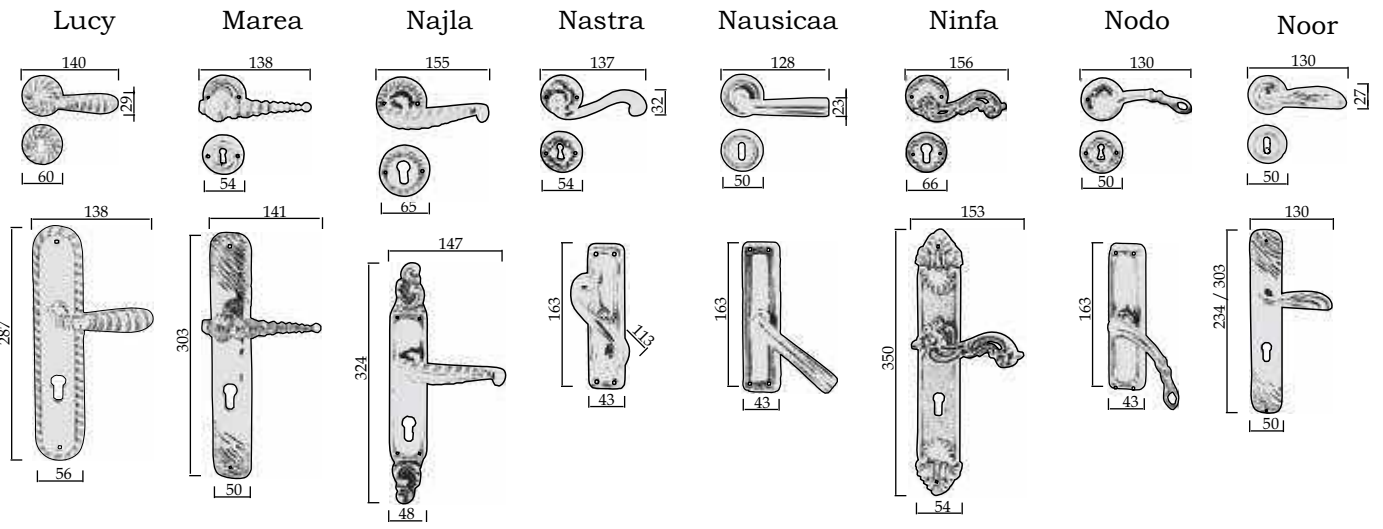
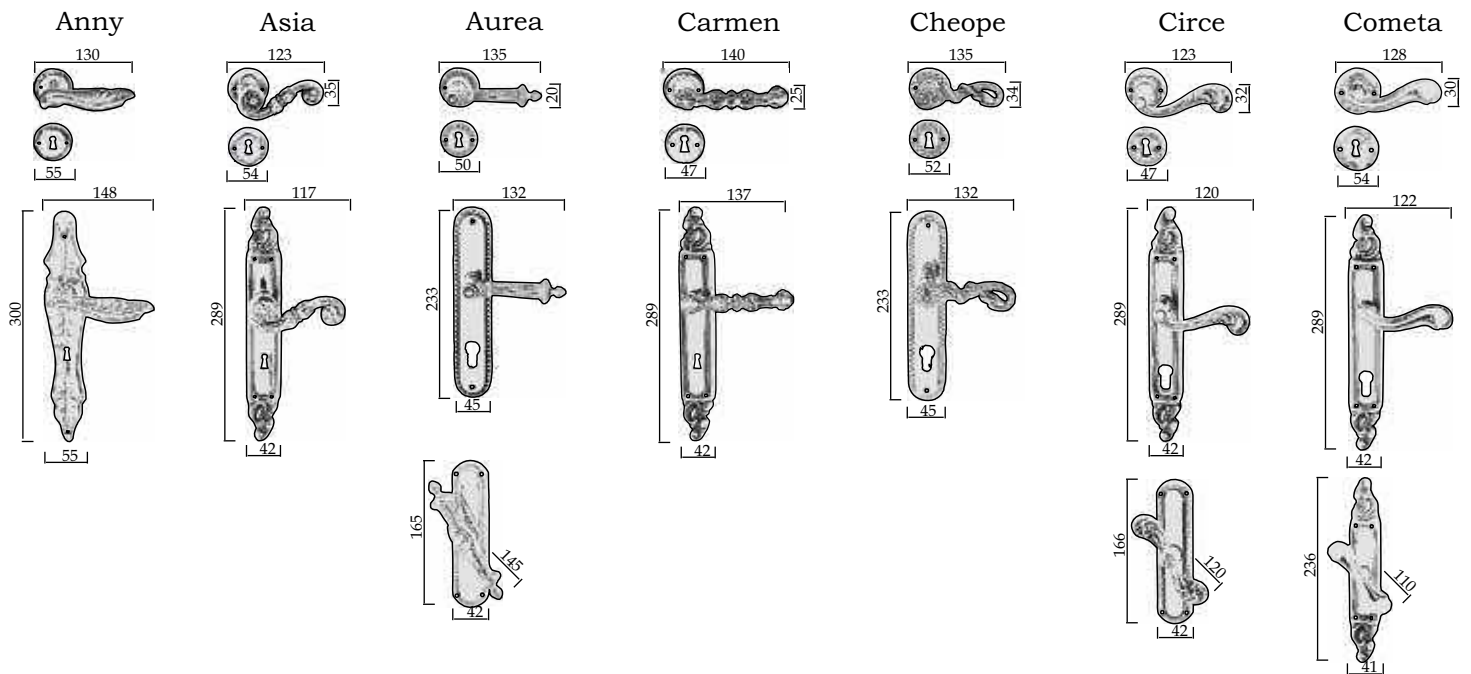

**Finiture - Finishes**

Oro Lucido  
Polished Brass



Oro Antico  
Antique Brass



Argento Antico  
Antique Silver



Placcato Oro 24 K  
24 K Gold Plated



Bronzo Satinato Opaco  
Satinated Bronze Matt



Rame Antico  
Antique Copper





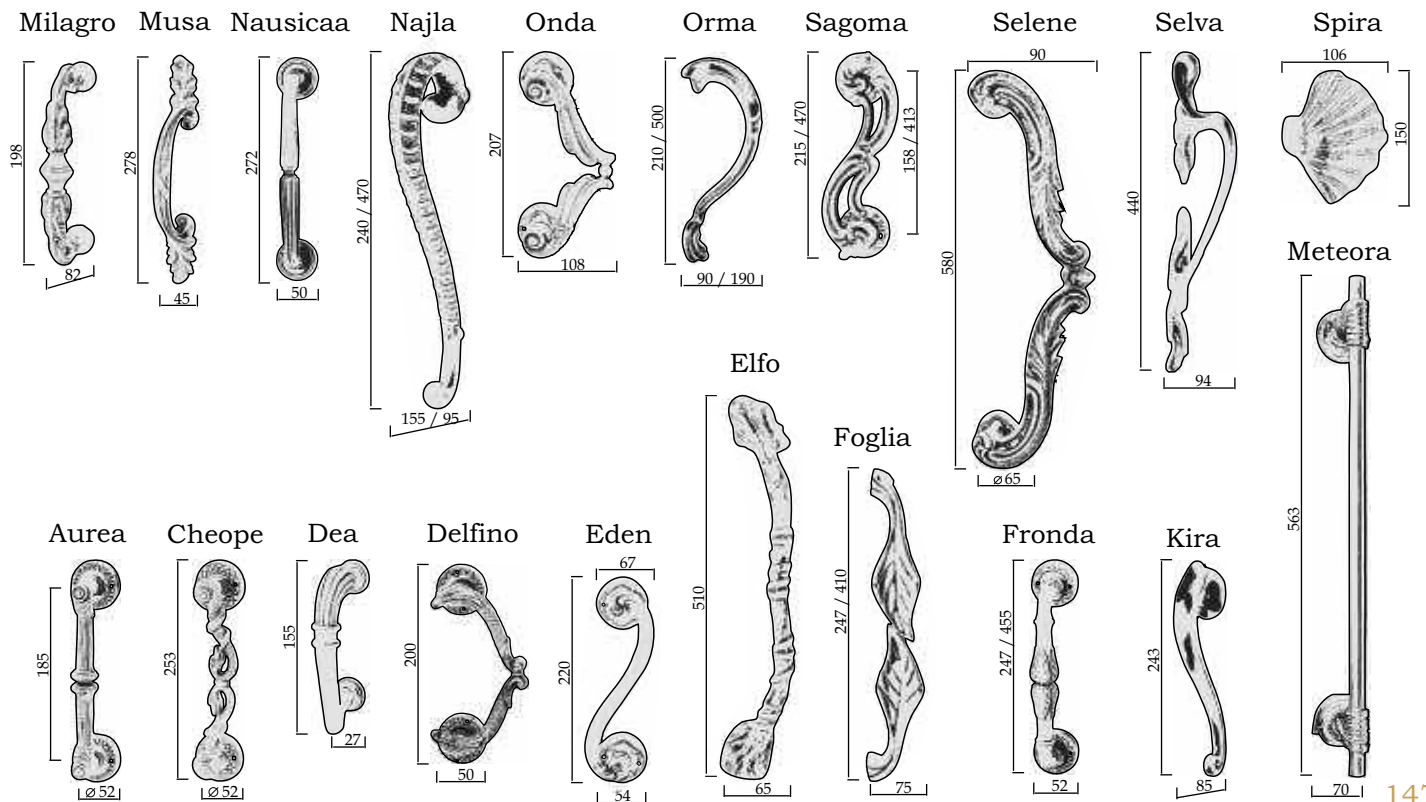
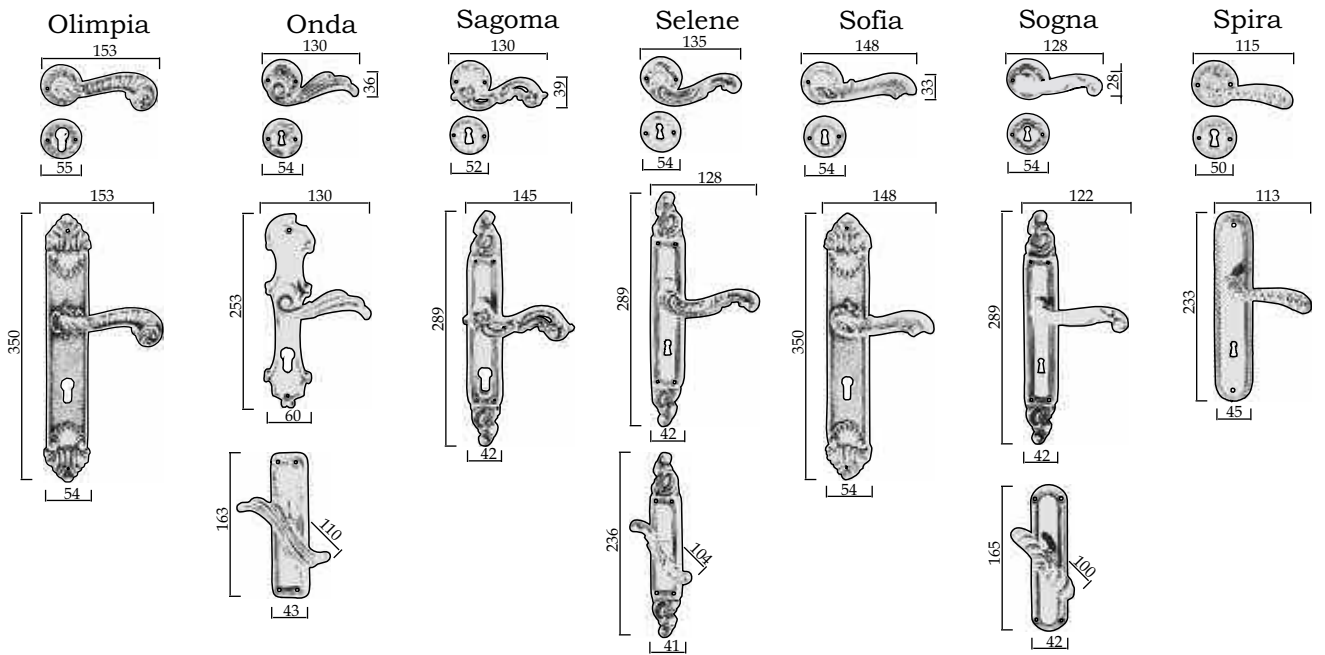
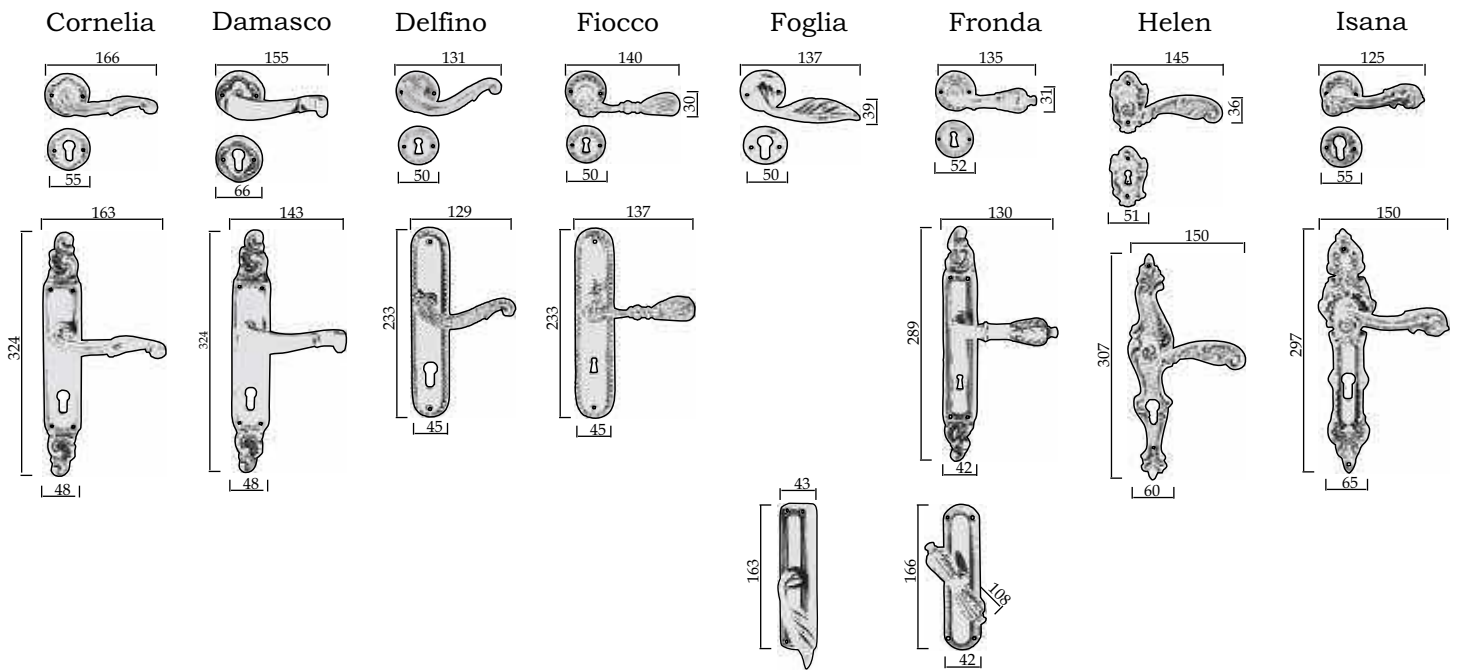

Wati

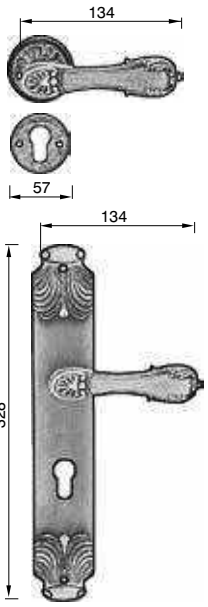

Alexandra

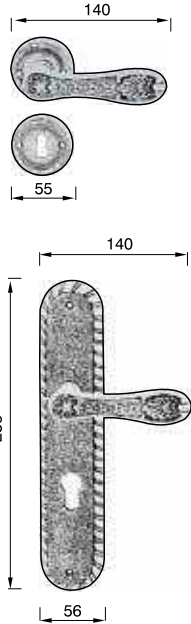

Alyssa

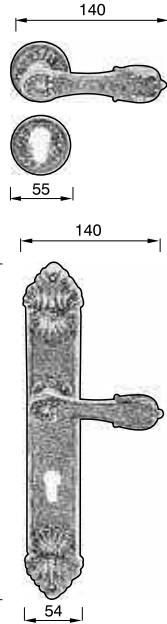

Audrey

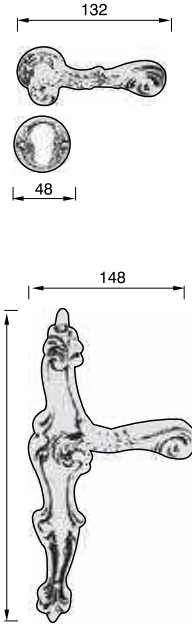

Carlotta

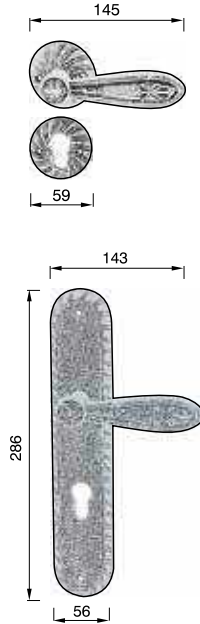

Monnalisa

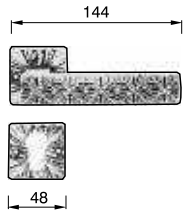

Morena

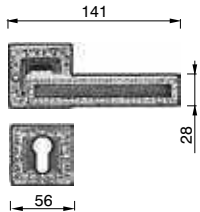

Nadine

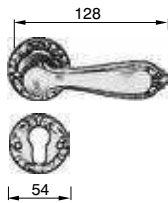

Nicole

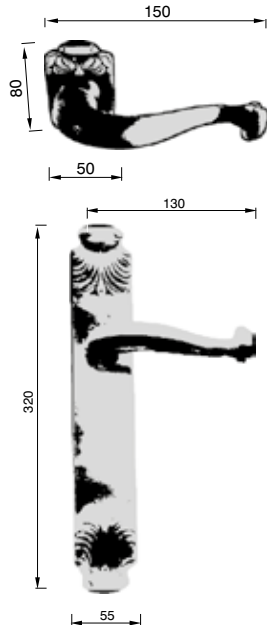

Noemi

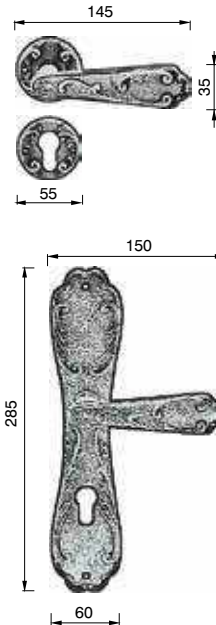

Ning

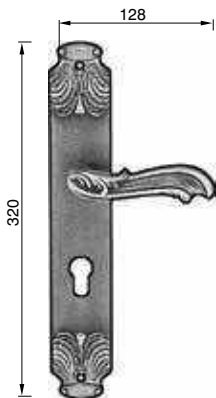

Thanya

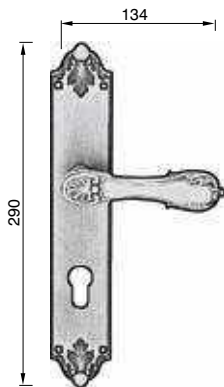

Federico

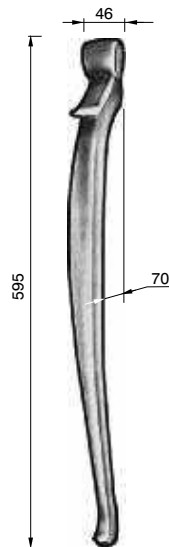

Airone

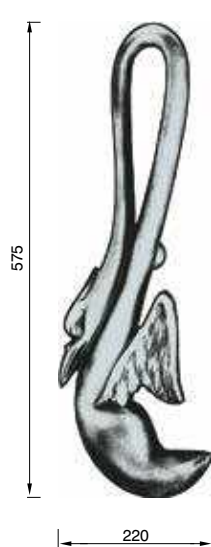

Domingo

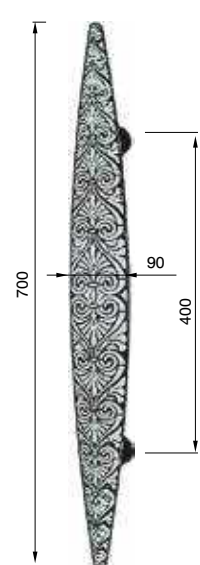

Domingo

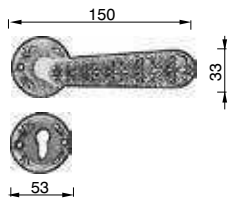

Elettra

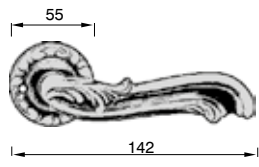

Elizabeth

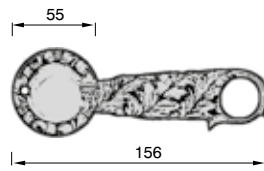

Jordan

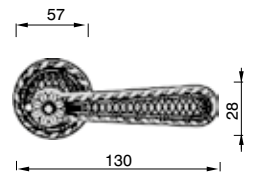

Sohan

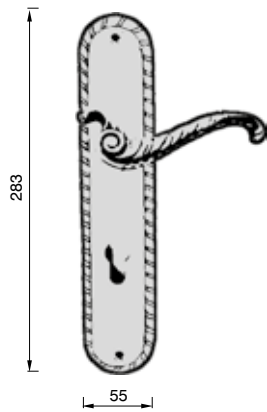
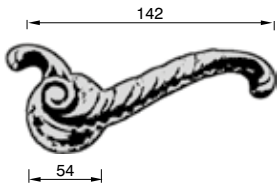

Stefani

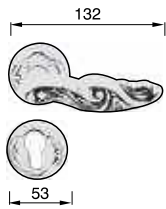

Stenny

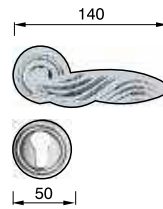

Monnalisa

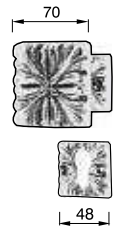

Gabriel

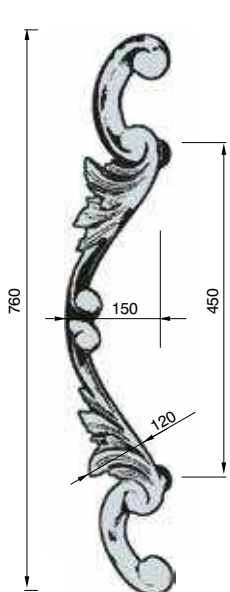

Joele

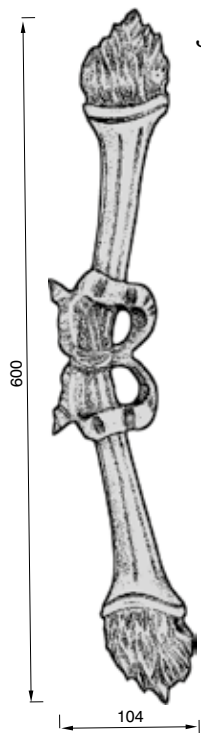

Lukas

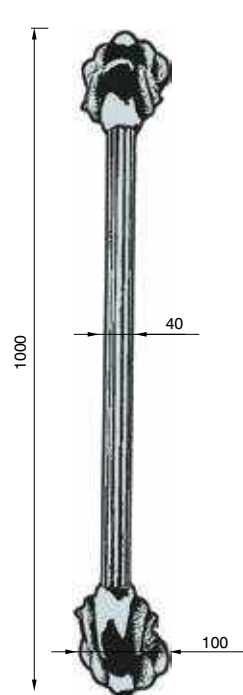

Monnalisa

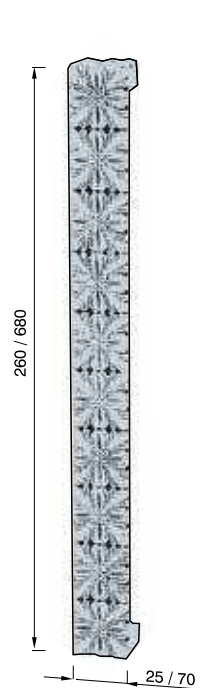



**La linea " opening "**  
**prodotta dalla ditta Poggi & Mariani s.r.l.**  
**e ideata dallo scultore Annibale Oste.**

La ditta **Poggi & Mariani s.r.l.** produce maniglie ed affini e, osservando con curiosità lo svolgersi delle attività di un artista come **Annibale Oste**, scultore e designer, ha deciso di inserire una linea a parte nella sua produzione.

Una linea che si rifacesse alle estrosità gestuali, classiche/moderne, di un moderno carico di citazioni e memorie, dello scultore stesso.

È nata la linea " **opening** ", ovvero apertura, inizio, partenza, avvio.

Si apre unuscio con la maniglia **Poggi & Mariani s.r.l./Oste** e si entra, con una cresciuta emozione, in un universo di segni, di forme, di malie.

Gli " oggetti " sono in ottone fuso a staffa, col vecchio sistema della fusione in terra francese.

Nasce un prodotto di alto artigianato, un artigianato che va ad estinguersi sostituito dal metodo della pressofusione più agile per costi e per velocità di produzione.

Ogni pezzo che, pertanto è creato singolarmente, viene raspinato e cesellato a mano per tirar fuori le luci, le ombre, le sagome, le tracce.

**Poggi & Mariani s.r.l. ed Annibale Oste**, in perfetta sintonia, garantiscono, con una simile cooperazione, un prodotto eccellente come qualità ed attraente come design e perché no, anche spiritoso.

**Annibale Oste**, scultore, nasce a Napoli dove vive e lavora. Il percorso della sua attività è stato ed è complesso, lungo, articolato, eclettico, febbrile.

La ricerca si è estesa dagli oggetti, ai gesti, alla luce, ai riverberi di un raggio e di una voce, riuscendo incredibilmente, a concretizzare e a raffigurare vento, luci, voci, oggetti.

La sua sperimentazione ha affrontato materiali come bronzo, alluminio, acciaio, legno e soprattutto vetroresina abbinata al bronzo.

L'interesse fondamentale di **Annibale Oste** è stato ed è l'osservazione di eventi naturali esaminati spesso in chiave umoristica, concettuale, sottolineando la decodificazione di miti ed espressioni classiche per ricostituire un'idea più flessibile ed affatto sconcertante.

Accanto al percorso della scultura vera e propria, nasce l'idea di articolare un particolare design da applicare a oggetti d'uso.

Viene fuori, allora, un continuo flusso di idee e di realizzazioni che hanno trovato applicazione nei più svariati campi dell'arredo.

I più diversi e sconvolgenti materiali danno vita, quindi, a situazioni uniche come ispirazione: oggetti, vasi, mobili, specchi ornati, maniglie ecc. costituiscono solo una tappa del tragitto imprevedibile e sempre più fantastico di **Annibale Oste**.

**The line " opening " produced by**  
**the firm of Poggi & Mariani s.r.l. and**  
**conceived by the sculptor Annibale Oste.**

*The work carried out by an artist like **Annibale Oste**, sculptor and designer, has aroused the interest of **Poggi & Mariani s.r.l.** manufacturers of door-handles and the like, who have thus decided to include a separate line in their production. A new line which would refer to the gestural skills of the sculptor himself, both classical and modern, a modernity rich in quotations and memories. Thus the " **opening** " line has been created.*

*Opening the door with a **Poggi & Mariani s.r.l. Oste** door-handle you enter and experience with ever increasing excitement, a universe of symbols, shapes, and spells.*

*" Objects " are in stirrup-melted brass produced by the old French method of sand-moulding. This is a highstandard handcrafted product, the like of which is dying out because of the use of die-casting which makes production cheaper and quicker. Each part, which is therefore created singly is filed and chased by hand, to bring out lights, shadows, forms and lines. Working in such perfect harmony **Poggi & Mariani s.r.l. and Oste** guarantee a product excellent in quality, attractive in design, and, why not, even witty.*



*The sculptor **Annibale Oste** was born in Naples, where he lives and works.*

*The course of his activity was, and still is, complex, long, rich, eclectic and feverish.*

*His search for creation has led him from objects to gestures, light, the reflection of a ray and the echo of a voice, and he has succeeded unbelievably in giving form and expression to the wind, lights, voices and objects.*

*He has worked with various materials, such as brass, aluminium, steel, wood and, above all, fibre-glass with brass.*

***Annibale Oste's** main interest has always been, and remains, the observation of natural events which he examines in a humorous, conceptual way, decoding myths and classical expressions to reconstruct an idea, more flexible and wholly disconcerting. Alone with his real activity as a sculptor, he had the idea of creating a particular design which could be applied to functional objects.*

*There results continuous flow of ideas and creations which have found an application in the numerous fields of fixtures and fittings.*

*The most different and unusual materials are then used to give form to situations unique in their inspiration: objects, vases, furniture, ornate mirrors, door-handles, etc. represent only a stage in the unpredictable career of **Annibale Oste**.*

# Linea Opening

Maniglie - <i>Door Handles</i>	154
Pomoli - <i>Knobs</i>	180
Cremonesi - <i>Window Handles</i>	184
Maniglioni - <i>Pull Handles</i>	190
Appendiabiti - <i>Coat Hook</i>	198
Accessori - <i>Accessories</i>	204
Copriavvolgibili - <i>Cover Coil for Blinds</i>	204
Coprinterrottori - <i>Switch Cover</i>	204
Manigliette - <i>Handles</i>	207
Chiavi - <i>Keys</i>	208
Nottolini - <i>WC Set</i>	210
Pomolini - <i>Cabinet Knobs</i>	211



A seguire solo il mio istinto, direi di non simpatizzare con gli artisti-designer, con quei pittori e scultori le cui opere hanno anche una valenza pratica: c'è in essi qualcosa di spurio, di indeciso, un grado di approssimazione sia sul versante dell'opera "disinteressata" sia su quello del prodotto avente una funzione, ecc. D'altra parte la suddetta scelta istintiva impedirebbe a me e ad altri di capire che: a) molti designer hanno esordito come pittori e scultori conservando una indelebile, positiva traccia di questa loro primitiva esperienza; b) molti artisti, pur senza alcuna velleità progettuale, sono comunque dotati di uno spirito di progetto tale da influenzare la cultura del design; c) nuovi materiali e tecniche entrano nella produzione di manufatti più dalla sperimentazione artistica che da quella della mera tecnologia; d) le conformazioni degli artisti-designer aprono nuove prospettive al disegno industriale proprio in quanto nate da una "logica" diversa: ignorano la legge di gravità, l'equilibrio statico, le simmetrie costruttive, ecc.; e) in definitiva siamo in presenza di artefici il fine ultimo è quello di fissare oltre una funzione pratica soprattutto un'immagine.

Certo, la vexata quaestio del dualismo tra arte pura ed applicata rimane negli artefici cui mi riferisco e con essa rimane il vecchio compromesso; tuttavia con una distinzione che vorrei qui proporre: nella vicenda del gusto contemporaneo sono riconoscibili operatori che associano, in generale banalmente, il pratico con l'estetico, ed altri che, per così dire, derogano dall'una come dall'altra categoria proponendoci oggetti che di fatto le trascendono entrambe, quasi appartenessero ad un mondo "terzo" rispetto a quello dell'arte e del design.

Tale mi sembra l'opera di Annibale Oste, nella quale si trovano anche molti dei punti sopra menzionati. A quale artista può venire in mente di annullare tutta una conformazione plastica per risolverla in un oggetto avente un'utile finalità talvolta minima? E a quale designer di progettare degli oggetti in cui l'immagine plastica domina quasi totalmente la pratica funzione? Chi, come Oste, costruisce tavoli sostenuti solo da un drappo di stoffa o innalza pareti di tessuto modellati dal vento? Che poi quel sostegno di tavolo o quella parete siano di Fibreglass, ossia resina poliestere più lana di vetro (una materia plastica che diventa rigida e solida una volta modellata) si direbbe questione secondaria: ciò che conta è che la fantasia di Oste abbia visto in tale materia il modo di realizzare e fissare stabilmente un'immagine. Ma l'uso del condizionale è imposto dall'apporto più specifico dell'artista, donde la ripetizione della domanda: quale designer penserebbe ad un drappo per reggere un tavolo? Oltre alle categorie del pratico e dell'estetico, un'altra coppia conviene richiamare nella interpretazione degli oggetti che si trovano nel laboratorio di Oste: quelle che, con termini lati ed estesi, designano rispettivamente il "razionale" ed il "barocco", ciascuno dei quali è attraversato e, diciamo così, "tradito" da questo originale artefice. Vi sono infatti dei manufatti da lui elaborati (siamo in presenza ovviamente di una lavorazione artigianale, almeno allo stato di prototipo) di pretto stampo "analitico", per dirla con Menna. Essi ricordano l'astrattismo geometrico, gli elementi dell'arredo funzionale, persino accenti costruttivisti e neoplastici, ma basta la presenza di un dettaglio - una piccola figura naturalista, una sfera posata su un piano, un drappo di Fibreglass appunto - per smentire la matrice razionalista dell'ispirazione. Più segnata certamente è la matrice che inclusivamente chiamo "barocca". Tale è infatti tutto il repertorio espressionista, surrealista, dadaista, popartista, ecc. che Oste adopera per dar forma alle sue immagini. Ma il suo fine non è di "meravigliare", come vuole il popolare obiettivo del Barocco, quanto piuttosto di dimostrare la fattibilità di oggetti o parti di oggetti nei modi da altri impensati. Il suo è un immaginario del possibile, dove tutto si può fare, tutto costruire e a "cose fatte", nulla risulta affidato al caso. In tal senso, in questo mondo niente affatto ineffabile, la presenza della razionalità non è certo trascurabile.

*Instinctively, I would say that I did not like artist-designers, those painters and sculptors whose works also have a practical value: there is something false and indecisive about them, a certain superficiality both as regards a "disinterested" work and a functional product etc. On the other hand, such an instinctive choice would prevent me and others from understanding that: a) many designers having begun their career as painters and sculptors, retain something lasting and positive from their previous experience; b) many artists, even if they have no ambition in the field of design, are nevertheless endowed with such a spirit. That they influence design culture; c) new materials and techniques for manufactured products result more from artistic experimentation than from technology alone; d) the characteristics of artist-designers give new possibilities to industrial design, because they come from a different "logic". They disregard the law of gravity, static equilibrium, construction symmetry, etc; e) after all these are craftsmen whose ultimate goal is to create an image over and above the practical function.*

*Certainly, the "vexata quaestio" of dualism between pure and applied art remains in the artists I am referring to and with it, the old compromise; yet, with a distinction that I would like to propose here; as regards contemporary taste, we can distinguish artists who combine, generally in a banal way, the practical with the esthetic, and others who, so to speak, deviate from one, as well as from the other category. Proposing objects, which are actually beyond both of them, almost as if they belonged to a "third" world with respect to those of art and design. Such seems to me the work of Annibale Oste, in which many of the above mentioned points can be found. Could it enter such an artist's mind to reduce a work of art to an object whose end is sometimes minimal as regards utility? Likewise, would a designer consider creating objects whose artistic image almost completely dominates their practical function? Who, as Oste does, constructs tables supported only by pieces of cloth or puts up walls made of material modelled by the wind? The fact that the table support or the wall is made of fibre-glass, that is polyester-resin plus glass wool (a plastic material which becomes solid and hard after modellation) could be considered secondary: what matters is that Oste's imagination has seen how to realise and stabilize an idea with this material. The use of the conditional tense is imposed by the specific contribution of Oste. The artist, hence, to repeat the question: what designer would think of use cloth to support a table?*

*Besides practical and esthetic categories, we should consider another pair in the interpretation of objects in Oste's workshop: that which, in broad terms, designates the "rational" and the "baroque", respectively, each of which is contained and in a certain sense, "betrayed" by this original craftsman. There are, in part articles produced by him (obviously, we are dealing with artigianal works, at least at the prototype stage) of pure "analytical" stamp, in Menna's words. They remind us of geometrical abstractionism, of elements of functional fixtures and fittings, even of constructivistic neo-plastic tones; only the presence of a detail, a small naturalistic figure, a sphere on a piano, a fibre-glass cloth, is sufficient to negate the rationalistic matrix of his inspiration. The matrix which we call "baroque" is certainly more evident. Such is in fact the whole repertoire of expressionism, surrealism, dadaism, pop-art, etc., used by Oste to form his images. But his purpose is not that of "surprising", as was the common aim of baroque-art, but rather to demonstrate the practicability of objects or parts of objects in ways never thought of by others, his aim is to imagine the possible, where everything can be made and constructed, and when everything is done, nothing seems to be left to chance. So in this world which is not absolutely ineffable, the presence of rationality is certainly not negligible.*



Ma se le categorie suddette - non arte pura, né applicata, non classico, né barocco - non bastano a spiegare la produzione di Oste, quale altra chiave può servire alla sua decodificazione? L'assenza di preconetti, l'indifferenza verso precise fonti di ispirazione e quest'idea di un magico laboratorio dov'è possibile realizzare tutto mi inducono a ritenere che la chiave, la caratteristica invariante della sua produzione sia il gioco; un gioco, talvolta ingenuo, talaltra scaltrissimo che egli effettua con occhio nuovo con mezzi e modalità particolari. Infatti, solitamente si gioca con elementi già pronti (i pezzi degli scacchi, le carte, i dadi, ecc.), il giocatore limitandosi in pratica ad escogitare, nell'ambito delle regole combinatorie, anch'esse date e codificate, delle personali strategie atte a vincere l'avversario. Nel caso di Oste, egli si avvale di quegli elementi già pronti, tutto il bagaglio figurativo preesistente antico e moderno, sconvolgendone tuttavia le regole combinatorie come se, poniamo, si giocasse a dama ma coi pezzi degli scacchi e viceversa. Cosicché il fruitore dei suoi oggetti, riconosce, per così dire, gli elementi di partenza, ma non come sono stati combinati a conformazione avvenuta. In sostanza siamo ancora in presenza della dialettica norma-deroga, questa volta però resa più esplicita e comunque più ricorrente, come si è detto, in tutto il campionario della sua produzione.

Il tema più recente di quest'ultima riguarda le maniglie con gli annessi derivati: le cremonesi, i pomoli, gli occhelli per le chiavi, ecc. Trattandosi di un tema unico, l'eclettismo dell'ispirazione è più evidente: la serie presenta modelli naturalisti, neoclassici, liberty, protorazionalisti, funzionalisti, ecc. Ma, anche qui ed ancora una volta, i dati di partenza, gli stilemi preesistenti sono combinati o utilizzati in maniera affatto diversa che negli stili originali. Infatti, ad eccezione di qualche pezzo - il nastrino neoclassico girante intorno ad un simmetrico perno - in cui il fattore morfologico sembra trovare una maggiore integrazione funzionale con l'oggetto, quasi tutti gli altri trascendono la principale norma del design, quella cioè per cui il " significato " di un prodotto deriva o non è altro che la sua funzione. Significato che ciascuno stile secondo il proprio gusto, di fatto ha conservato. Oste deroga ancora una volta: quale che sia la memoria dei passati oggetti, le sue maniglie e i suoi accessori, oltre a legare forma e funzione, sono oggetti che " rappresentano " anche qualcos'altro: un'ala, un nastro appunto, due tondi di bronzo legati insieme da una bronzea, morbida fettuccia, talvolta un elemento zoomorfo o fitomorfo, ecc. Anche in passato si idearono elementi mimetici negli oggetti d'uso, ma questa introduzione del " rappresentativo " era sempre dovuta al desiderio di trovare una corrispondenza stilistica fra i vari pezzi d'arredo di un ambiente, in definitiva ad una questione di mera assonanza. Viceversa, nel caso in esame, la vocazione a rappresentare è limitata al singolo oggetto, alla singola maniglia, secondo la logica propria dell'industrial design, che riconduce tutte le istanze allo specifico pezzo che sarà quantificato teoricamente all'infinito e si può collocare praticamente ovunque. In tal modo Oste, da un lato recupera la " decorazione " attraverso la rappresentazione, ma questa si esaurisce di volta in volta nella singola copia di un prodotto, nella sfera morfologica che le è propria, senza ulteriori rimandi ad altri oggetti, magari alla stessa maniglia della porta accanto. Insomma ogni suo pezzo è una scultura funzionale che tenta di esaurirsi in sé senza rinvii; allo stesso modo del tavolo retto da un drappo che non impone affatto stilisticamente lo stesso sostegno per le sedie o la credenza da ubicarsi nello stesso ambiente. Concludendo, Oste entra ed esce dalla normativa del design con un metodo che sopra ho definito proprio del gioco; un gioco tuttavia con effetto " spiazzante ", impreveduto, ingenuo e sapiente, piacevole ed inusuale, ecc. così come capita in definitiva a chi è capace di " far parlare " le cose.

*But, if the above - mentioned categories - pure, applied, classic and baroque do not sufficiently explain Oste's work, what other key can be used to decode it? The absence of preconceived ideas, indifference towards precise sources of inspiration, and his concept of a magic workshop, where it is possible to realize everything, leads me to believe that the key, the constant characteristic of his production, is a game, a game sometimes naive, sometimes very cunning which he creates with a new vision, using particular materials and methods. Generally, we play with ready-made elements (chesspieces, cards, dice, ect.) and in practice, the player is limited to think up personal strategies, within a given and codified set of rules, in order to beat his opponent. In Oste's case, he of course makes use of ready-made elements, from the whole pre-existing figurative stock, both ancient and modern, but he upsets their rules, as if, for instance, he were playing draughts with chesspieces or vice-versa. Thus the user of his objects recognizes, so to speak, the starting pieces, but he does not know how they have been combined in their resulting form. Substantially, we are still dealing with the dialectic of norm and exceptions, which, in the whole range of Oste's work, however is more explicit and recurrent, as was said before.*

*Most recently he has been working with door-handles and their parts: cremonese bolts, pommes, key-eyelets, etc. As he is dealing with a single subject, the eclecticism of his inspiration becomes more obvious: the series presents models of naturalistic, neo-classic, liberty, early rationalistic and functionalistic style. But here, once again, the concepts he starts from and their pre-existing stylistic features are combined and used in quite a different way than originally. In fact, except for some pieces - for example, a neo-classic ribbon which is rolled around a symmetrical pin - where the morphological element seems to have a better functional integration with the object, almost all the other pieces go beyond the principle norm of design, that is that the " significance " of an object derives from, or simply is, its function; a significance that has been maintained by each style, according to its own characteristics. Once again, Oste deviates from this principle: however objects were in the past, his door-handles and his accessories, apart from combining form and function, are objects which also " represent " something: a wing, a ribbon, two brass medallions laced together by smooth brass, sometimes a zo-or-phytomorphic element etc. Even in the past, mimetic elements in functional objects could be found, but this introduction or " the representative " was always due to the desire to find a stylistic harmony among the various fixtures and fittings in an environment, in short, it was a question of here assonance. On the contrary, in Oste's case, the wish to represent is limited to the single object, the single door-handle, according to the logic of industrial design, where all the requirements refer to the specific part, which, theoretically, will be infinitely reproduced, and be placed practically everywhere. Thus, on one hand, Oste re-establishes " decoration " through representation, but every time, this is contained in each single copy of the product, in its own morphological sphere, without further reference to other objects, be it the same door-handle as one beside it. Finally, each of his pieces is a functional sculpture which tries to be self-contained, in the same way that the table supported by a piece of cloth does not stylistically impose the same support for the chairs or the sideboard which are to be placed in the same room.*

*In conclusion, Oste plays with the norms of design using a method which I have defined above as a game yet, a game whose effect is " disorientating ", unexpected, naive and wise, pleasing and out of the ordinary etc., as happens with those who have the gift of making objects " speak ".*



---

# Line Opening

Maniglie

*Door Handles*

## Apologia *Apology*

O uomini, quegli tra voi è sapientissimo il quale, come Socrate, abbia riconosciuto che in verità la sua sapienza non ha nessun valore; ecco perchè ancora oggi io vo dattorno... Poichè sembrami non ci sia nessuno, io vengo così in aiuto al dio dimostrando che sapiente non esiste nessuno.

(Platone, Apologia di Socrate)

*Oh men! The wisest among you is the one who has admitted, as did Socrates, that his wisdom has no value; that is why, still now, I stroll around... Because it seems to me that there is nobody, thus I come to god's help, showing that no man is wise.*

(Plato, Socrates' Apology)



---

# Cibele

## *Cybele*

Sgorga dalla terra come una girandola e si arrotola e fa scaturire la vita nello spazio, in un tempo senza direzione. Dal passato al futuro, forse?  
Forse il tempo è come la coscienza, come presenza, dell'anima che si distende tra memoria e immaginazione, come durata, in uno spazio che è vuoto infinito o idea astratta o reale, assoluto...

*Gushes and spirals out from the earth, rolls up and produces life in space, in a time without direction. From past to future, may be?  
Perhaps, time is like conscience, like the presence of the soul which stretches out between memory and imagination, like duration in a space which is infinite emptiness or an abstract or real idea, absolute...*

---

opening

*Fopp'edizioni s.r.l.*



---

Cibele art. 011



---

# Dafne

## *Daphne*

Rincorsa in una voglia di tutto, un virgulto diviene la  
casta ninfa che la terra trattiene  
per stabilire una tregua, un pò perentoria.

Anassagora usa l'intelletto per non trovarsi in  
difficoltà a spiegare con cause naturali i fenomeni.

*Consumed by a desire for everything, the seedling  
becomes the virgin nymph that the earth keeps to  
establish a truce, a little peremptory.*

*Anaxagoras uses intellect to overcome difficulties  
which arise while explaining such phenomena by  
natural causes.*

opening

*Fopp'edizioni s.r.l.*



Dafne art. 012

---

# Diana

## *Diana*

Mi piacerebbe parlarvi di Diana e di Atteone: nomi che nell'animo del lettore possono richiamare poche o molte cose: una situazione, atteggiamenti, forme, il soggetto per un quadro, un'ombra di leggenda... (Klossowski, Il bagno di Diana). La freccia e l'arco si incrociano indissolubili, come conquista e alibi di un'avventura e di un'irrequietezza implacabili.

*I would like to talk about Diana and Actaeon: names, that may remind the rider of a few or several things: a situation, attitudes, forms, the subject for a picture, a shadow of legend... (Klossowski, Diana's bathe). The arrow and the bow cross each other and cannot be untied, like the conquest and alibi of an adventure and an implacable restlessness.*

opening

*Fopp'edizioni s.r.l.*



Diana art. 001



---

# Entropia

## *Entropy*

Come i fiumi scorrono verso il basso, le pietre rotolano dai pendii, il moto cessa in conseguenza dell'attrito: tutti i moti relativi cessano. I corpi caldi si raffreddano, quelli freddi si scaldano.

Questo... è il corso inevitabile degli eventi nel mondo che ci circonda.

(Landau, Kitaigorodoskij, La fisica per tutti).

*Like rivers flow downwards and stones roll down from slopes, motion stops due to friction: all relative motions end. All hot bodies become cold and cold ones heat up: the temperatures of all bodies are equal.*

*This... is the inevitable course of events in the world which surrounds us.*

*(Landau, Kitaigorodoskij, Physics for everybody).*

opening

*Topp'illuminazioni s.r.l.*



Entropia art. 005

---

# Frammento

## *Fragment*

Per il soggetto il gesto dell'abbraccio amoroso sembra realizzare, per un momento, il sogno dell'unione totale con l'essere amato...

Momento dell'affermazione: per un po', anche se limitatamente, disordinatamente, qualcosa è andato per il verso giusto.

(R. Barthes, Frammenti di un discorso amoroso).

*The love embrace seems to realize, just for a moment, the dream of complete union between lovers. A moment of affirmation: for a short while, even if limited and disordered, something has gone right.*

*(R. Barthes, Fragments of a love conversation).*

opening

*Topp'illusioni s.r.l.*



Frammento art. 013



---

# Koreia

## *Koreia*

Lo spettacolo occidentale è antropomorfo, in esso gesto e parola formano un unico tessuto (R. Barthes).  
Così congiunto, in questa identità di movimento, il gesto conduce ad una suadente forma viva e naturale che può divenire un onnipotente feticcio.

*Western performance is anthropomorphic, here gesture and word form a single cloth (R. Barthes).  
Combined in this way, with this identity of movement, gesture leads to a tempting, living and natural form, which may become an omnipotent fetish.*

opening

*Topp'illuminazioni s.r.l.*



Koreia art. 006

---

# Logos

## Logos

Nella filosofia greca ha due significati che tuttavia si raccolgono in uno solo: pensiero e parola. Ne deriva la tesi di alcune posizioni greche (es. Eraclito, Stoici) secondo cui l'universo costituisce un tutto ordinato in virtù di una ragione (cosmica) che in esso si rivela e si esprime.

*In Greek philosophy, Logos has two meanings, which, however, can be found in a single one: thought and word. From this point some Greek beliefs (E.G. Heraclitus, the Stoics) according to which, the universe is an ordered whole, by virtue of a cosmic ratio, that is revealed and expressed in it.*

opening

*Toppi'illusioni s.r.l.*



Logos art. 008



---

# Metafora

## *Metaphor*

Nel libro terzo della Retorica, Aristotele osserva che ogni metafora sorge dall'intuizione di un'analogia tra cose simili.

Aristotele, come si vede, fonda la metafora sulle cose e non sul linguaggio. (Borges, Storia dell'eternità).

Alcuni non concordano.

*In the third book of Retic, Aristotle points out that every metaphor is created by the intuition of an analogy between similar things.*

*As we can see, Aristotle bases metaphor on things and not on language (Borges, History of eternity).*

*Some people disagree with this.*

opening

*Toppi' Illuminazioni s.r.l.*



Metafora art. 004

---

# Prometeo

## *Prometheus*

Una scintilla fu rapita dal figlio di un Titano nella fucina di Efesto. E i mortali si difesero dal gelo, combatterono le belve e plasmarono i metalli.

Alla torpida età dell'argento succede la feconda e fremente età del bronzo.

*A spark was stolen by the son of a titan from Hephaestus' forge. Human beings defended themselves against the cold, fought against beasts and moulded metals. From the torpid silver age follows the fertile and agitated brass age.*

opening

*Fopp'edizioni s.r.l.*



Prometeo art. 003



---

# Temi

## *Themis*

Sapiente scorre lontana a spargere nell'aere gli umani destini. Una eco, tornando, ne trattiene la foga e si placa carica di tensioni e di vibrazioni. Una dottrina dell'Eterno Ritorno si formula: "In un tempo infinito, il numero delle permutazioni possibili non può non essere raggiunto e l'universo deve per forza ripetersi".

*Wisely runs afar to scatter human destinies in the air.  
Returning, an echo holds back its impetus and grows calm, full of tension and vibration.  
The doctrine of the Eternal Recurrence says:  
"In an infinite time, the number of possible changes has to be reached, and the universe must repeat itself".*

opening

*Toppi'illusioni s.r.l.*



Temi art. 009

---

# Testudo

## *Testudo*

Ha il corpo tozzo, col tronco racchiuso in una robusta corazza, costituita da squame ossee, rivestite da pietre cornee. Si muove lentamente ma, secondo il paradosso di Zenone, giunge prima di Achille alla meta. A quel punto è saggia ed elegante e può escogitare fantasie innumerevoli durante il percorso.

*Its body is stocky, its trunk enclosed in a solid cuirass, consisting of bony scales covered with horny stones, it moves slowly, but according to Zeno's paradox, it reaches the goal before Achilles. At that point, it is wise and elegant and can think up innumerable fantasies along the way.*

opening

*Toppi & C. s.p.a.*



Testudo art. 010



---

# Zefiro

## Zephyr

Se il gesto diviene un segno, quasi casualmente, diviene anche una riflessione di estremo rigore.

Il tempio di Segesta si impone sulle azalee mielate.

Il profumo di queste reca omaggio al tempio dorato ed esse, ritte in una dignità magistrale, si inarcano al soffio del messaggero della primavera, dalle ali di farfalla.

*If gesture becomes a sign, it also becomes, almost by chance, an extremely deep reflection. Saegesta's temple stands with an imposing appearance on the honey-coloured azaleas. The perfume of these pays homage to the golden temple and, standing upright with a masterful dignity, they slightly bow, blown by the butterfly wings of the messenger of spring.*

opening

*Topp'illuminazioni s.r.l.*



Zefiro art. 002

---

# Line Opening

Pomoli  
*Knobs*

## Allegory *Allegory*

Una verità riposta ed inafferrabile alla mente umana si rintraccia in simboli o immagini che ne evocano il più intimo significato. Nelle sacre pitture il metodo allegorico offre l'interpretazione delle verità rivelate da Dio, conciliabili, in tal modo con le verità filosofiche.

*A truth remote and elusive to the human mind is to be found in symbols or images, evoking its most intimate meaning. In sacred writings the allegorical method offers the interpretation of truths revealed by god, which are therefore reconcilable with philosophical truths.*

## Faustus *Faustus*

Faustus vende la sua anima a Mefistofele, emissario di Lucifero per ventiquattro ore di piacere e di potere. Non gli rimangono che pochi istanti di vita. Vorrebbe pentirsi, pregare, sperare, ma non può più. L'armonia dei pitagorici prevede comunque che l'anima trasmigri in altri corpi e viva sempre nuove vite.

*Faustus sells his soul to Mephisto, Lucifer's emissary, for twenty-four hours' pleasure and power. He has no more than a few instants to live. He would like to repent, pray, hope, but he cannot any more. However, the harmony of Pythagoreans foresees that the soul will be passed on the other bodies and will always live new lives.*

## Aporia *Aporia*

In senso figurato è il dubbio, la problematicità. In generale: problema senza soluzione perchè qualunque via d'uscita si cerchi, porterà sempre ad una contraddizione. Gli Scettici sospendono ogni giudizio, rinunciano ad ogni certezza teoretica, così il saggio trova la sua più perfetta imperturbabilità.

*In a figurative sense this means doubt, uncertainty. In a general, a problem without solution because it will always lead to a contradiction whichever the way. Sceptics suspend judgements, abandon any theoretical certainty, thus the wise man finds his most perfect imperturbability.*

Allegory art. 017 PF



Faustus art. 018 PM



Aporia art. 019 PM



Allegory art. 017  
Aporia art. 019  
Faustus art. 018

---

## Serenade

### *Serenade*

La cetra di un aedo, l'arpa toccata da mani vellutate o la "serenade" di chi non si assopisce mai. Endimione, che, per decreto di Giove, dorme senza fine in una grotta nei monti della Carla, viene contemplato ogni notte da una Selene estasiata.

*A Greek poet's harp, or that touched by velvety hands or "the serenade" to which one could never fall asleep. Endymion, who will sleep for ever in a cave in the Carla mountains, as Jupiter decreed, is gazed upon by an enraptured Selene.*

## Tamerlane

### *Tamerlane*

Come la corona di un re che spietatamente agogna ad ogni possibile potere. E i suoi narratori C. Marlowe e E.A. Poe ne subiscono un fascino immenso.

... O cuore avido! Da te io ereditai anche, con la fama, la tua parte più peritura, quel che appassisce e muore, divorante vampa tra le gemme del mio trono... (E. A. Poe).

*Like the crown of a king who cruelly thirsts for any possible power. C. Marlowe and E.A. Poe, his narrators, were deeply fascinated by this. ... Oh eager heart! From you I inherited together with fame, the part of you more transient, that which fades and dies, and ardent flame among the gems of my throne... (E. A. Poe).*





Serenade art. 016 PF



Tamerlane art. 014 PF

---

# Line Opening

Cremonesi  
*Knobs*

## Metafisica

### *Metaphysics*

Dal greco: che è al di là da ciò che appare fisicamente.  
È forse la filosofia che discetta sull'essenza della realtà,  
oltre ciò che è accolto dall'esperienza.  
È da considerare che l'essenza del reale ha infinite interpretazioni.

*From Greek: that, which is beyond physical appearance.  
It is perhaps philosophy, which deals with the existence of reality,  
besides that which is included from experience.  
We should realize that the essence of the real has infinite interpretations.*

## Metamorfosi

### *Metamorphosis*

Penso a quelle di Ovidio che in quindici libri scrive un poema epico di derivazione alessandrina. Il dolore dei suoi personaggi è tranquillo ed anche le passioni amorose sono pacate. Dal caos all'apoteosi di Cesare si narra la storia dell'umanità, evitando la monotonia.

*I am thinking of Ovidio's, who in 15 books writes an epic poem of Alexandrian derivation. His characters' woe is calm, as are their passions of love.  
From chaos to Cesar's apotheosis, he tells the story of humanity, without it being monotonous.*



Metafisica art. 023 C



Metamorfosi art. 022 C

Metafisica art. 023  
Metamorfosi art. 022

---

## Nexus

### *Nexus*

Nell'avvincente era dei grandi progetti fantastici si presenta una storia di nessi tra l'umano e la sua possibile, perfetta replica. Tale piano - Nexus - dà l'avvio al mondo dei replicanti, che, in spoglie terribilmente affascinanti, conquistano, con un'aria assai temibile il povero mondo dei deboli uomini.

*In the fascinating time of incredible projects, is found a story of "Nexes" between a human and his possible, perfect copy. This nexus-project gives rise to the world of clones, who taking on a terribly fascinating appearance, conquer, with their fearful airs, the poor world of weak men.*

## Pizia

### *Pythia*

Il nome della Sibilla che pronunciava gli oracoli nel santuario di Delfo perchè Apollo da bimbo uccise il serpente inviatogli contro da Giunone. Il serpente pitone. E con la sua pelle ricoprì lo scanno della profetessa.

*The name of Sybil, who pronounced oracles in the Delphian temple, because Apollo, as a child, killed the python, that Juno had sent against him, and with its skin he covered the bench oh the prophetess.*





Nexus art. 025 C



Pizia art. 020 C

Nexus art. 025  
Pizia art. 020



---

## Sahara

### *Sahara*

Pare che gli spazi geografici determinino una certa differenza tra le razze umane. Ed è così che i Soafa nelle oasi del Suf piantano le loro palme da datteri in profondi crateri, ma la sabbia secca del deserto potrebbe ricoprirli di nuovo e la lotta con la natura non ha tregua.

*Geographical areas seem to cause certain differences in human races. Thus, Soafas plant their date-palms in deep craters in the Suf oases, but the dry sand of the desert could cover them again and the struggle against nature has no end.*

## Utopia

### *Utopia*

Che non è in nessun luogo. Tommaso Moro affida questo termine allo stato immaginario e ideale dove tutti vivono perfettamente felici. Anche Platone nella Repubblica e Campanella nella Città del Sole descrivono gli stati perfetti da usare come modello per l'umanità.

*Which is in no place. Tommaso Moro uses this term for an imaginary and ideal world, where every-one lives perfectly happily. Also Plato in his Republic and Campanella in his City of the Sun, describe perfect states which should be used as models for humanity.*



Sahara art. 024 C

Utopia art. 021 C



Sahara art. 024  
Utopia art. 021

---

# Line Opening

Maniglioni  
*Pull Handles*

## Alceo *Alcaeus*

Concittadino e contemporaneo, forse un po' più giovane di Saffo, Alceo (640-560 a.c.) nacque a Mitilene, nell'isola di Lesbo, da nobile famiglia.

Fu fiero avversario dei "tiranni" che in quel tempo si impadronirono del governo appoggiandosi al popolo. In battaglia abbandona lo scudo e si rifugia nei suoi carmi di rivolta, conviviali ed erotici.

*Fellow-citizen and contemporary, perhaps a little younger of Sappho, Alcaeus (640-560 b.c.) was born in Mitilen, on the Island of Lesbos, of a noble family.*

*He was fierce enemy of "tyrants", who in that time seized the government, supported by the people.*

*In the fight, he abandons his shield and takes refuge in his songs of revolt, both convivial and erotic.*

Alceo art. 026 MN  
250 mm



Alceo art. 026 MN  
600 mm



Alceo art. 026



Democrito art. 028 MN

## Democrito art. 028



---

opening

*Fopp'edizioni s.r.l.*



Frammento art. 013 MN

---

Frammento art. 013



Novel art. 029 MN

— Novel art. 029 —

opening

*Fopp' & C. s.p.a.*



Prometeo art. 003 MN

Prometeo art. 003

---

# Saffo

## Sappho

Contemporanea di Alceo, nasce a Mitilene, nell'isola di Lesbo. Si circonda di giovani amiche appassionate come lei dal canto e dalla musica. Nel Thiasos si incontra con la sua comunità nel culto delle Muse e di Afrodite. Inni, canti d'amore, epitalami, odi in metro saffico, incantano con l'armonia di una dolcezza sofferta.

*Alcaeus contemporary, she was born in Mitilen, on the Island of Lesbos. She surrounds herself with young friends who love, as she does, songs and music. In Thiasos, she joints her community, in the cult of the muses and Aphrodite. Hymns, love-songs, epithalamiums, odes in Sapphic metre fascinate with their harmony of suffered sweetness.*



Saffo art. 027 MN

Saffo art. 027



---

# Line Opening

Appendiabiti  
*Coat Hooks*

Azteca  
*Aztec*

Nel Messico i conquistatori spagnoli incontrarono l'ultimo fuoco di questa civiltà: gli atzechi di lingua nahuatl, allora nel pieno vigore della loro creatività e dominio. Avevano una scrittura propria, un calendario preciso e avevano raggiunto uno stadio di sviluppo urbano che li rendeva paragonabili agli egizi o ai babilonesi. Ampie vie, piramidi, scalinate, sculture monumentali, palazzi residenziali erano del Popolo del Sole prima della conquista.

*In Mexico, Spanish conquerors found the last traces of this civilization: the Aztecs, speaking in nahuatl, were at that time at the peak of their creativity and dominance. They had their own sculpture, a precise calendar and had reached a stage of urban development, which could be compared with Egyptians or the Babylonians. Wide streets, pyramids, stairways, monumental sculptures, residential buildings belonged to the People of the Sun before the conquest.*

opening

*Topp' illic' i'cc' i' s'rt.*



Azteca art. 035 AT

Azteca art. 035

---

## Inca

### *Inca*

Montaigne è stato commosso dal destino degli Inca. Nei suoi essais egli si allontana dal suo filosofico distacco per indignarsi delle gratuite crudeltà degli Spagnoli, ai quali rifiuta la gloria di vittorie troppo facili. Vi denuncia la cattiva fede di Pizarro, che fa trucidare Atahualpa, che aveva fedelmente pagato il suo riscatto (Metraux, Gli Inca).

*Montaigne was moved by the fate of the Incas. In his essays, he left from his philosophical indifference and became indignant about the gratuitous cruelties of the Spanish, whose victories he denies, considering them too easy. He denounces the bad faith of Pizarro, who causes the death of Atahualpa, the latter having faithfully paid his ransom (Metraux, Incas).*

## Indio

### *Indian*

Entriamo subito in una capanna di indio. Ci troviamo nel cortile che per gli indigeni costituisce la parte più importante della casa: qui, infatti, si svolgono i lavori quotidiani, qui si ripongono telai ed attrezzi. La luce, penetrando, rivela un totale disordine, paglia, pietre, una corda tesa su cui si ripongono indumenti. In un unico letto dormono genitori e figli.

*Let us immediately enter an Indians' hut. We find ourselves in the yard, which represents the most important part of a house for the natives. Here, in fact, the daily work is carried out, here, looms and instruments are kept. As it stretched cord, where cloths are hanging. In the same bed sleep parents and children.*



Inca art. 036 AT



Indio art. 037 AT

Inca art. 036  
Indio art. 037

---

## Macondo

### *Macondo*

Macondo era allora un villaggio di venti case di argilla e di canna selvatica costruito sulla riva di un fiume dalle acque diafane che rovinavano per un letto di pietre levigate, bianche ed enormi come uova preistoriche.

(G.G. Marquez, Cent'anni di solitudine).

*Macondo was then a village with about 20 clay and wild cane houses. Built on a river bank, whose clear water rushed over a bed of smooth stones, white and huge like prehistorical eggs.*

(G.G. Marquez).

## Maya

### *Maya*

Numerosi antropologi concordano nel riconoscere negli Tzotzil e negli Tzental i più puri discendenti dei Maya. Costoro ne riproducono l'idioma e i tratti morfologici. La loro vita è sottoposta a un elevato potere spirituale. Delle due anime una si avvicina progressivamente agli dei. Così, liberi da questa terra, rincorrono il Quetzal, l'antico uccello sacro che vive tra quelle cime di ghiaccio.

*Several anthropologists acknowledge the Tzotzil and Tzenal as being the purest descendants of Maya. These two peoples inherit Maya's language and morphological traits. Their life is subject to a high spiritual power. One of their two souls progressively approaches the gods. Thus, free from this earth, they pursue the Quetzal, the old sacred bird which lives among those icy mountains-tops.*





Macondo art. 038 AT



Maya art. 039 AT

Macondo art. 038  
Maya art. 039

---

# Line Opening

Accessori

*Accessories*

Copriavvolgibili  
*Cover Coil for Blinds*  
art. 040 CA



Coprinterruttori  
*Switch Cover*  
art. 040 CM

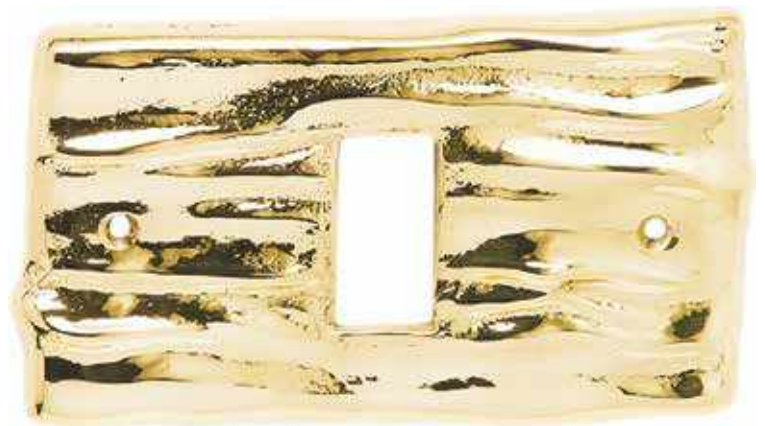

Copriavvolgibili - *Cover Coil for Blinds* art. 040 CA  
Coprinterruttori - *Switch Cover* art. 040 CM

---

# Line Opening

Manigliette

*Handles*

065 M



066 M



067 M

068 M



069 M



070 M



---

# Line Opening

Chiavi - Nottolini- Pomolini

*Keys - WC Set - Cabinet Knobs*



Chiave - Key art. 101



Chiave - Key art. 102



Chiave - Key art. 103



Art. 060 NT



Art. 061 NT

Pomolino  
Cabinet Knob  
art. 058 P



Pomolino  
Cabinet Knob  
art. 059 P

Pomolino  
Cabinet Knob  
art. 062 P



Pomolino  
Cabinet Knob  
art. 063 P

Apologia

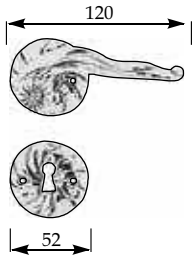

Cibele

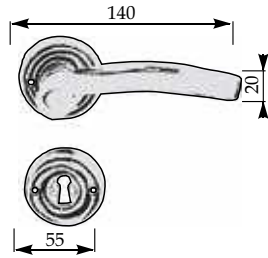

Dafne

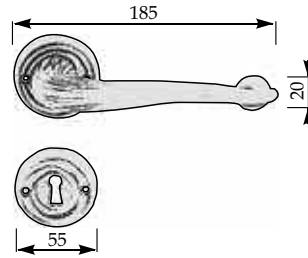

Diana

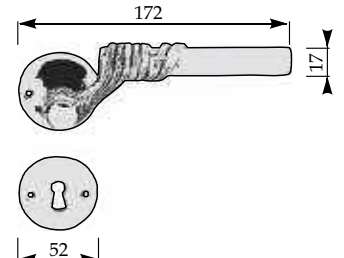

Entropia

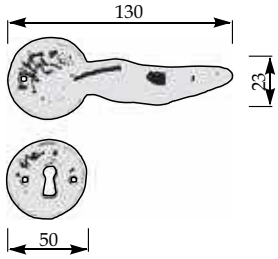

Frammento

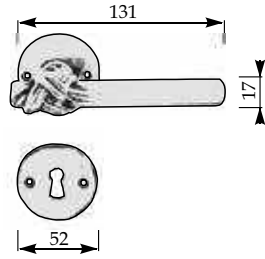

Koreia

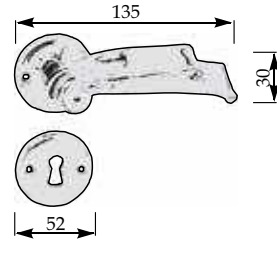

Logos

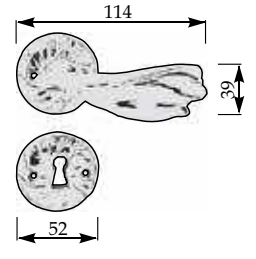

Metafora

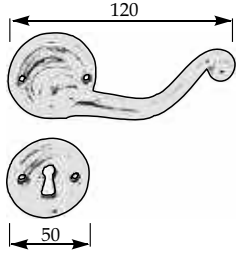

Prometeo

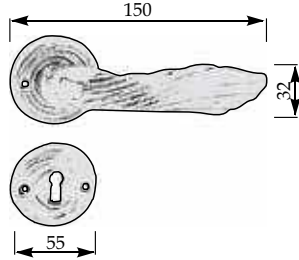

Temi

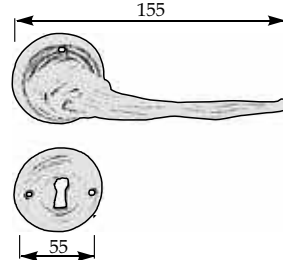

Testudo

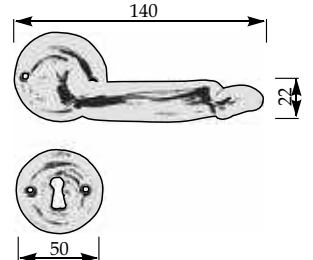

Zefiro

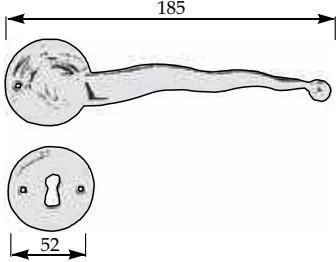

Prometeo MP

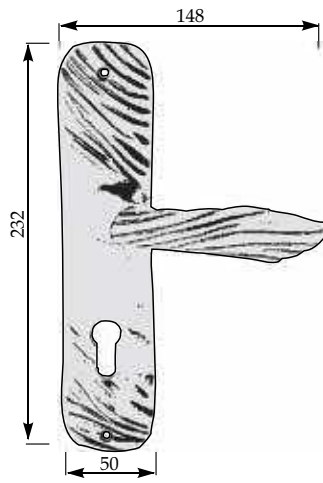

Allegory

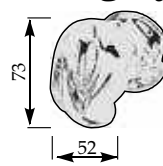

Aporia

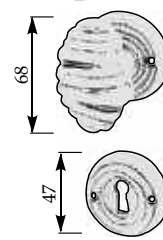

Faustus

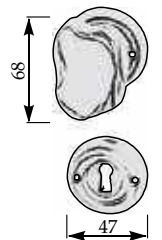

Serenade

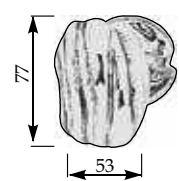

Tamerlane

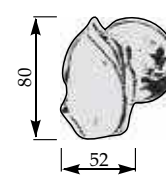

Metafisica

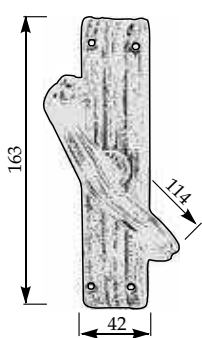

Metamorfosi

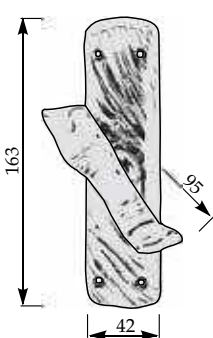

Nexus

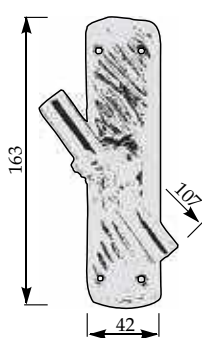

Pizia

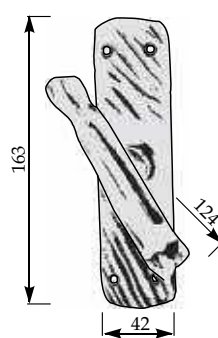

Sahara

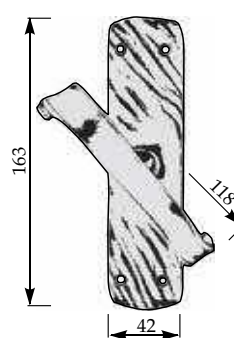

Utopia

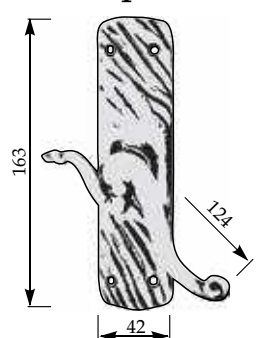

Finiture  
Finishes

Oro Lucido  
Polished Brass



Bronzo Satinato Opaco  
Satinated Bronze Matt



Placcato Oro 24 K  
24 K Gold Plated



Argento Antico  
Antique Silver





Alceo

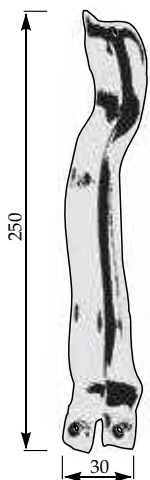

Democrito

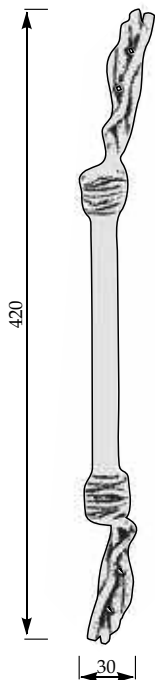

Frammento

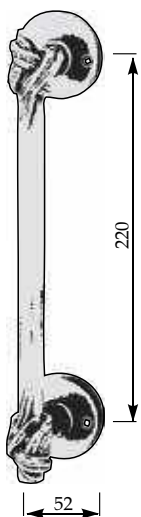

Novel

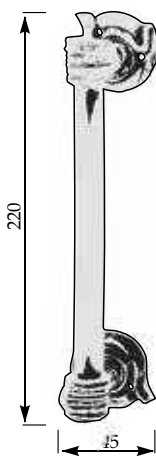

Prometeo

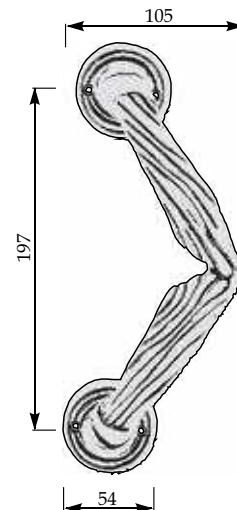

Saffo

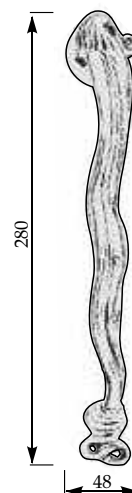

Azteca

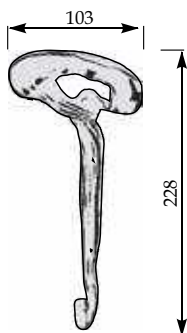

Inca

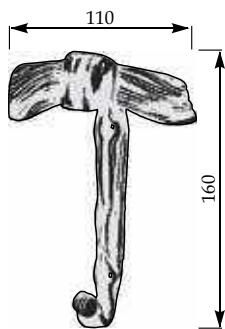

Indio

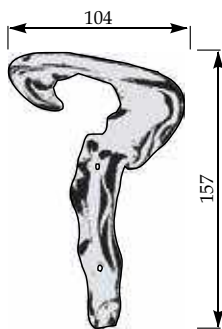

Macondo

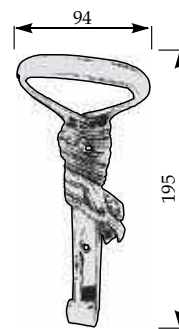

Maya

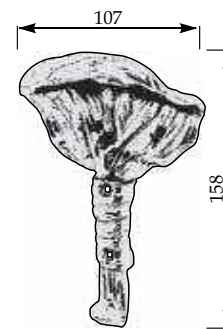

040 CA

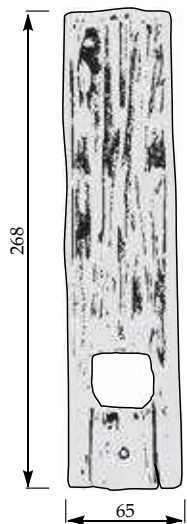

040 CM

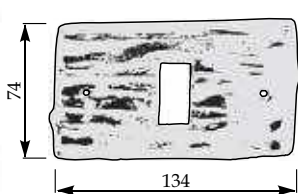

Pomolini  
Cabinet Knobs

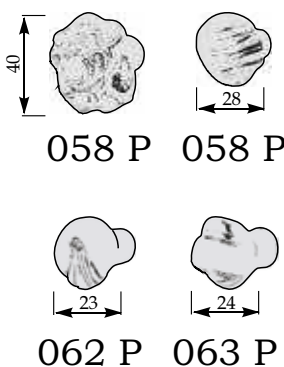

Chiavi  
Keys

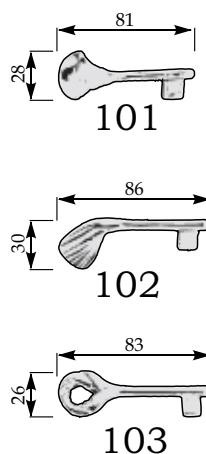

Nottolini  
WC Set

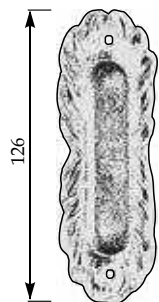
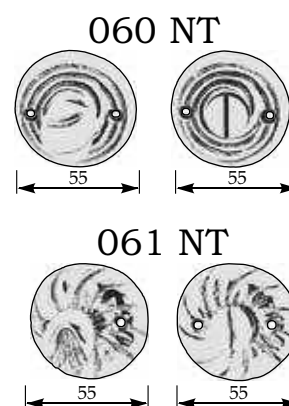

065 M

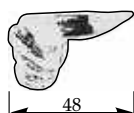

066 M



067 M

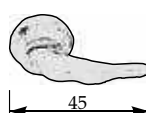

068 M

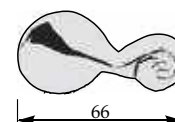

069 M

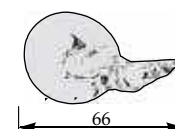

070 M

Maniglette - Cabinet Handles

# Linea Speciale

Pomolini - *Cabinet Knobs*

216



Vanilla art. Z1



Cannella art. Z2



Curry art. Z4



Ginger art. Z3



Paprica art. Z5



Pepe art. Z6



Sale art. Z7



Mirra art. Z8



Zafferano art. Z9



Salvia art. Z10



Timo art. Z11



trademark of

**dnd**

**handles  
with care**

[dndhandles.it](http://dndhandles.it)

**Dnd**

Località Piani di Mura, 2  
25070 Casto (BS) - Italia

T +39 0365 899113

F +39 0365 899118

[www.dndhandles.it](http://www.dndhandles.it)

